

DIN603

大半圆头方颈螺栓DIN603

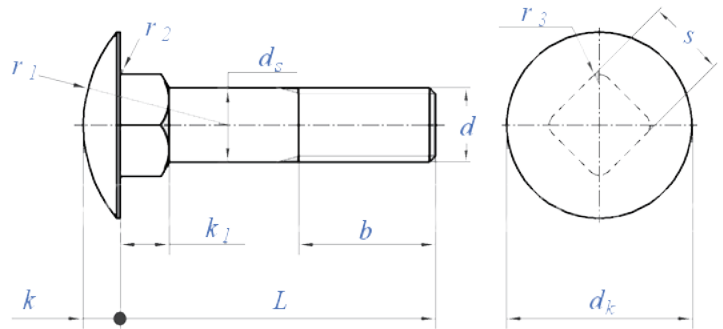

Thread Size	P pitch	b			dk		ds		k1		k		r1	r2	r3	s	
		L≤125	125<L≤200	L>200	max	min	max	min	max	min	max	min	≈	max	max	max	min
M5	0.8	16	22	/	13.55	12.45	5	4.52	4.1	2.9	3.3	2.7	10.7	0.5	0.75	5.48	4.52
M6	1	18	24	/	16.55	15.45	6	5.52	4.6	3.4	3.88	3.12	12.6	0.5	0.9	6.48	5.52
M8	1.25	22	28	41	20.65	19.35	8	7.42	5.6	4.4	4.88	4.12	16	0.5	1.2	8.58	7.42
M10	1.5	26	32	45	24.65	23.35	10	9.42	6.6	5.4	5.38	4.62	19.2	0.5	1.5	10.58	9.42
M12	1.75	30	36	49	30.65	29.35	12	11.3	8.75	7.25	6.95	6.05	24.1	1	1.8	12.7	11.3
M16	2	38	44	57	38.8	37.2	16	15.3	12.9	11.1	8.95	8.05	29.3	1	2.4	16.7	15.3
M20	2.5	46	52	65	46.8	45.2	20	19.16	15.9	14.1	11.05	9.95	33.9	1	3	20.84	19.16